

Návod/Manual

Přední hydraulické vidle 1/10 RC

www.powerprint3d.cz

- Děkuji za zakoupení mého produktu, věřím, že Vám bude dělat radost! 😊

Thank you for buying my product. I hope it will make you happy! 😊

Potřebné díly/Necessary parts

Din 7981 C st 2,2x6,5-----12x

Din 7981 C st 2,2x9,5-----8x

Din 7981 C st 2,2x13-----5x



- **JX Servo PS-5521MG 55g/0,16s/20kg**

- **Tisk na 3 perimetry/ print 3 perimeters**

Krok/step 1

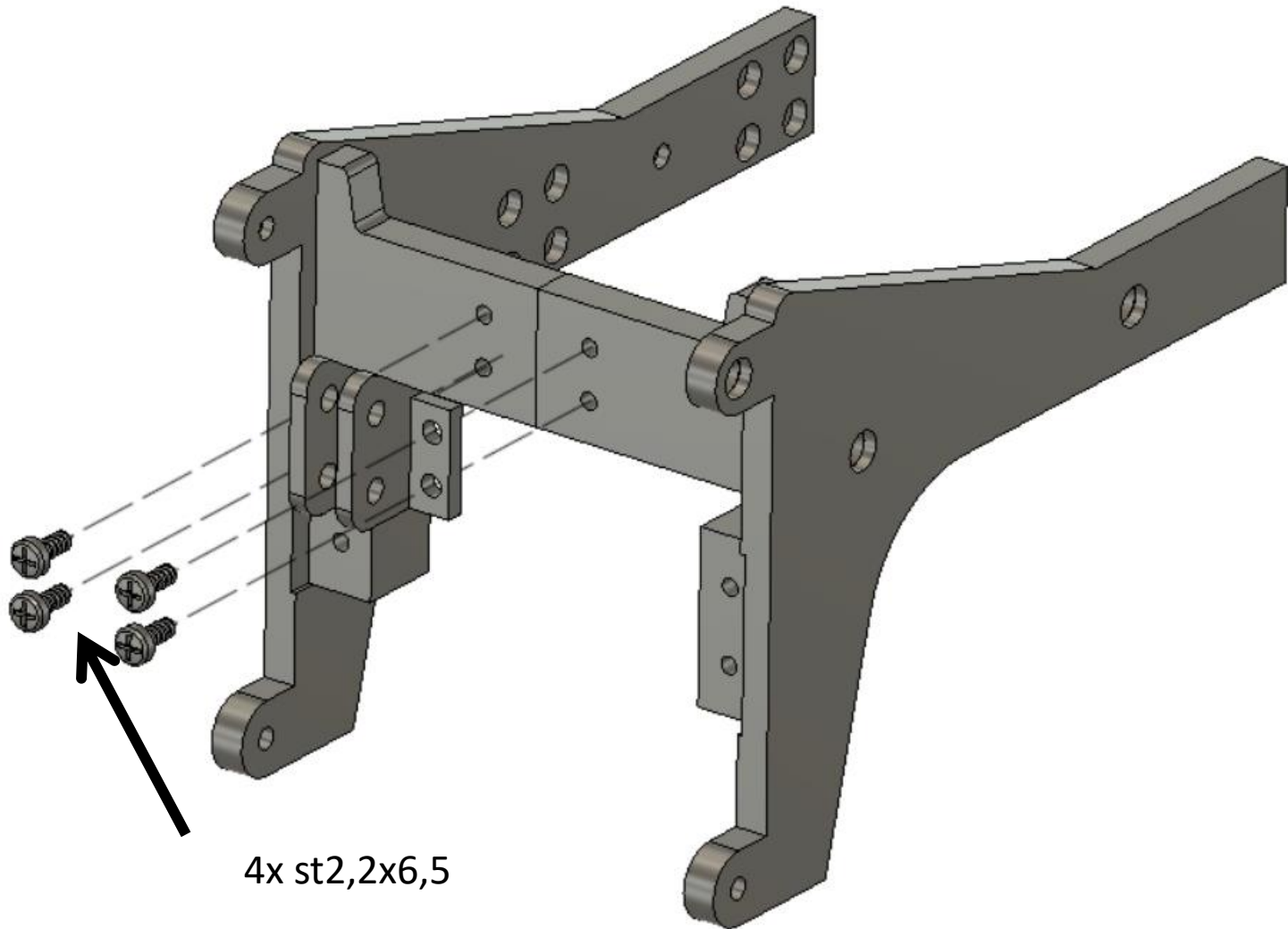

4x st2,2x6,5

Krok/step 2

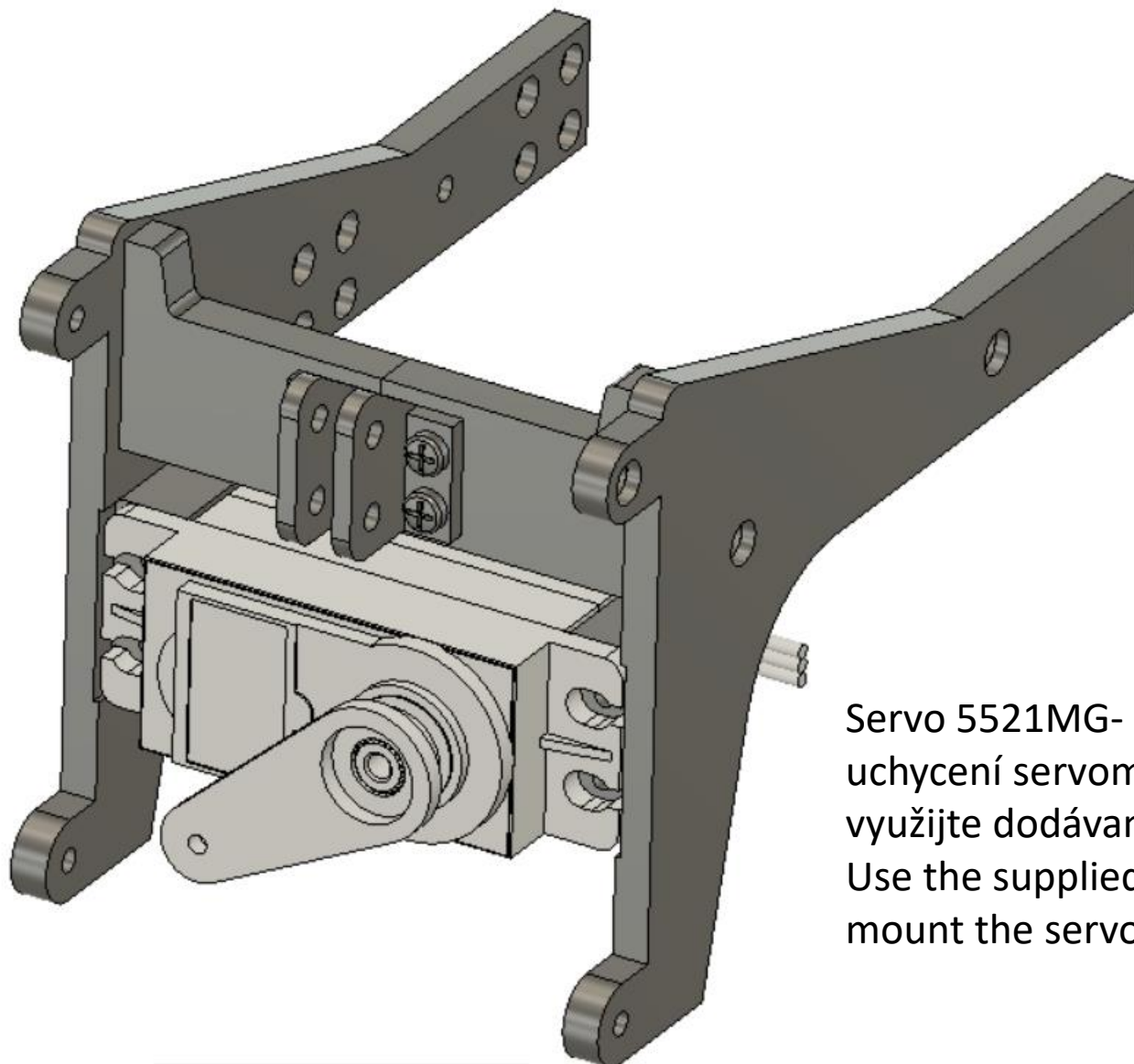

Servo 5521MG- Pro
uchycení servomotoru
využijte dodávané šrouby/
Use the supplied screws to
mount the servomotor

Krok/step 3

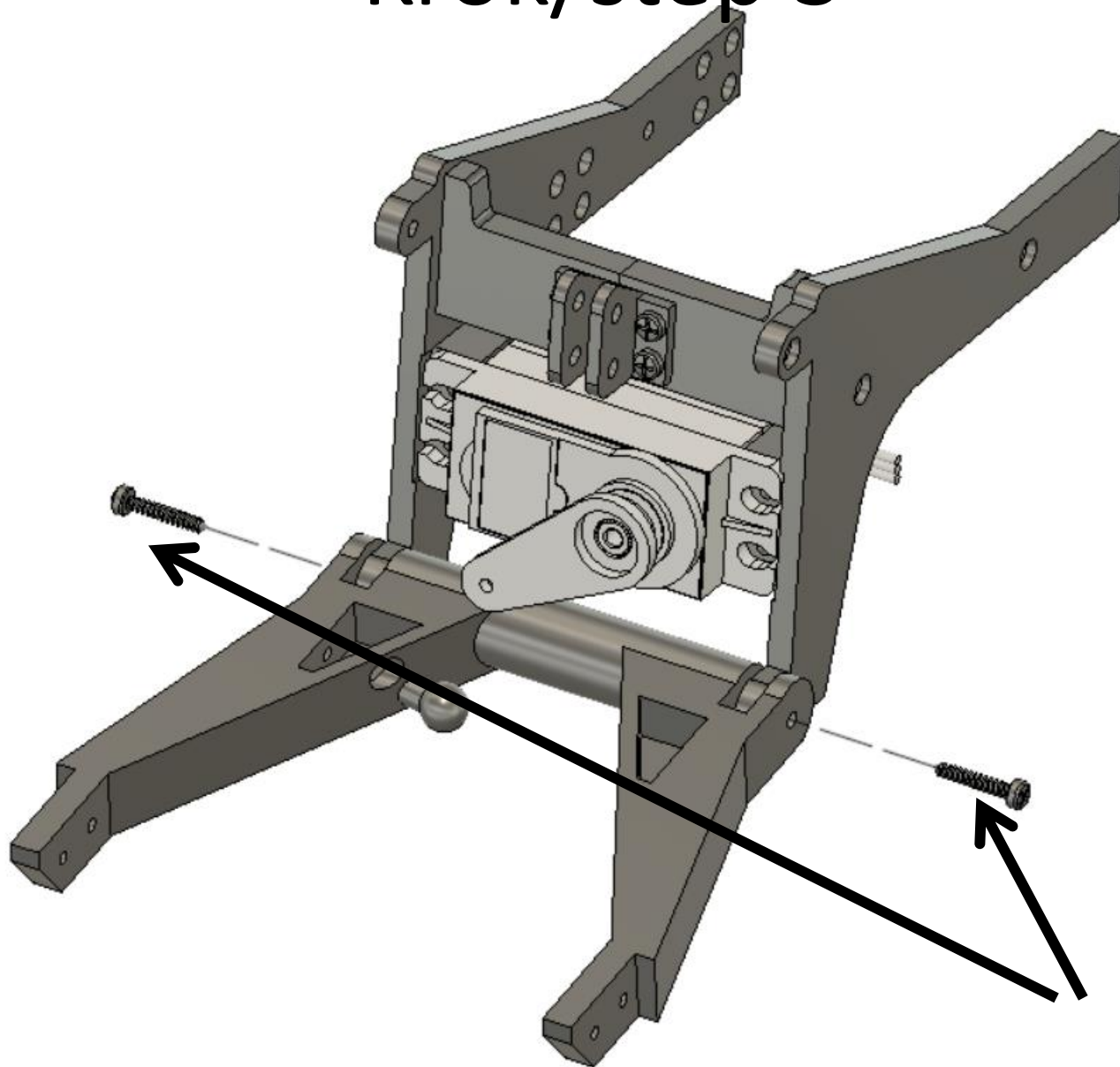

2x st2,2x13

Krok/step 4

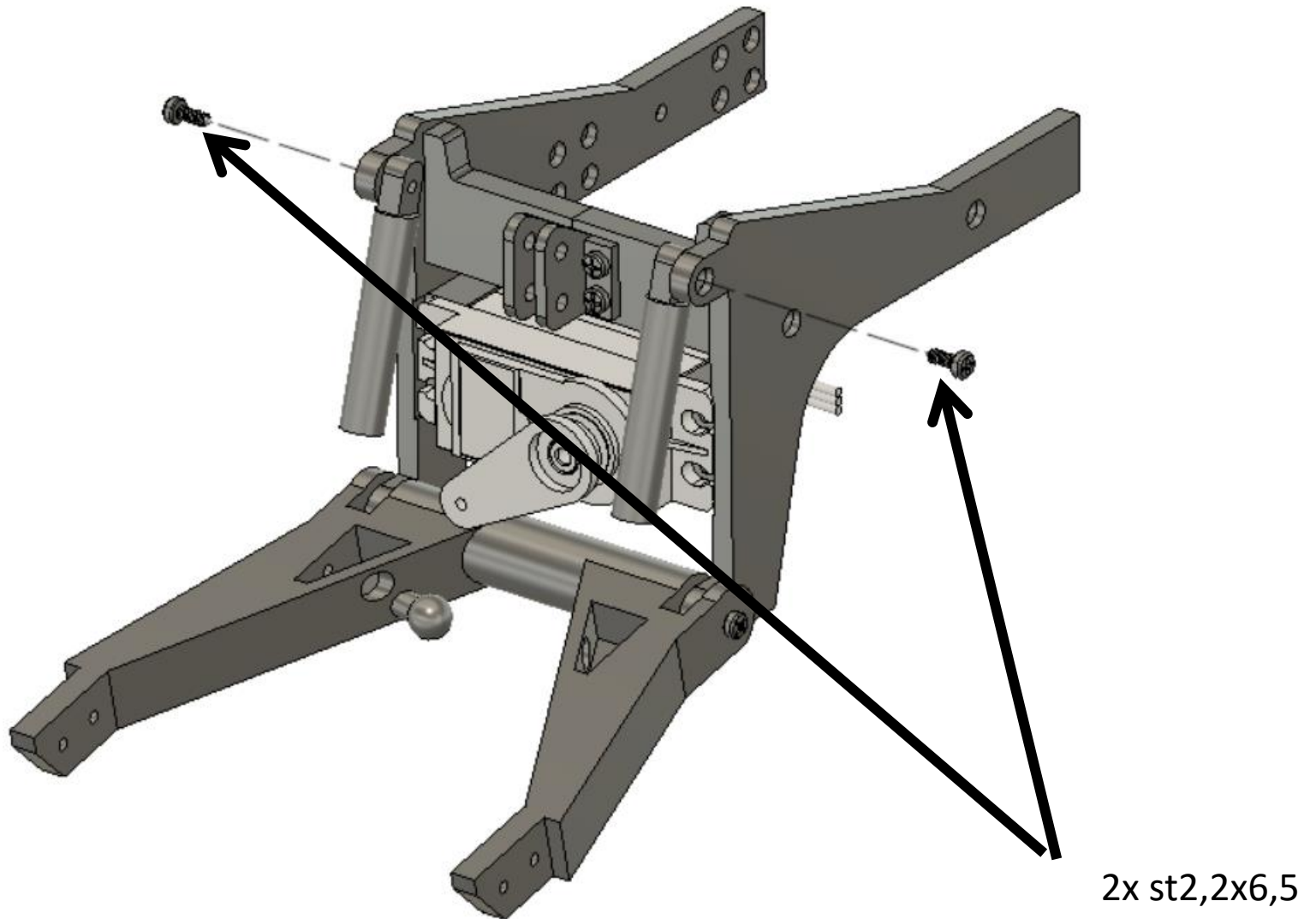

Krok/step 5

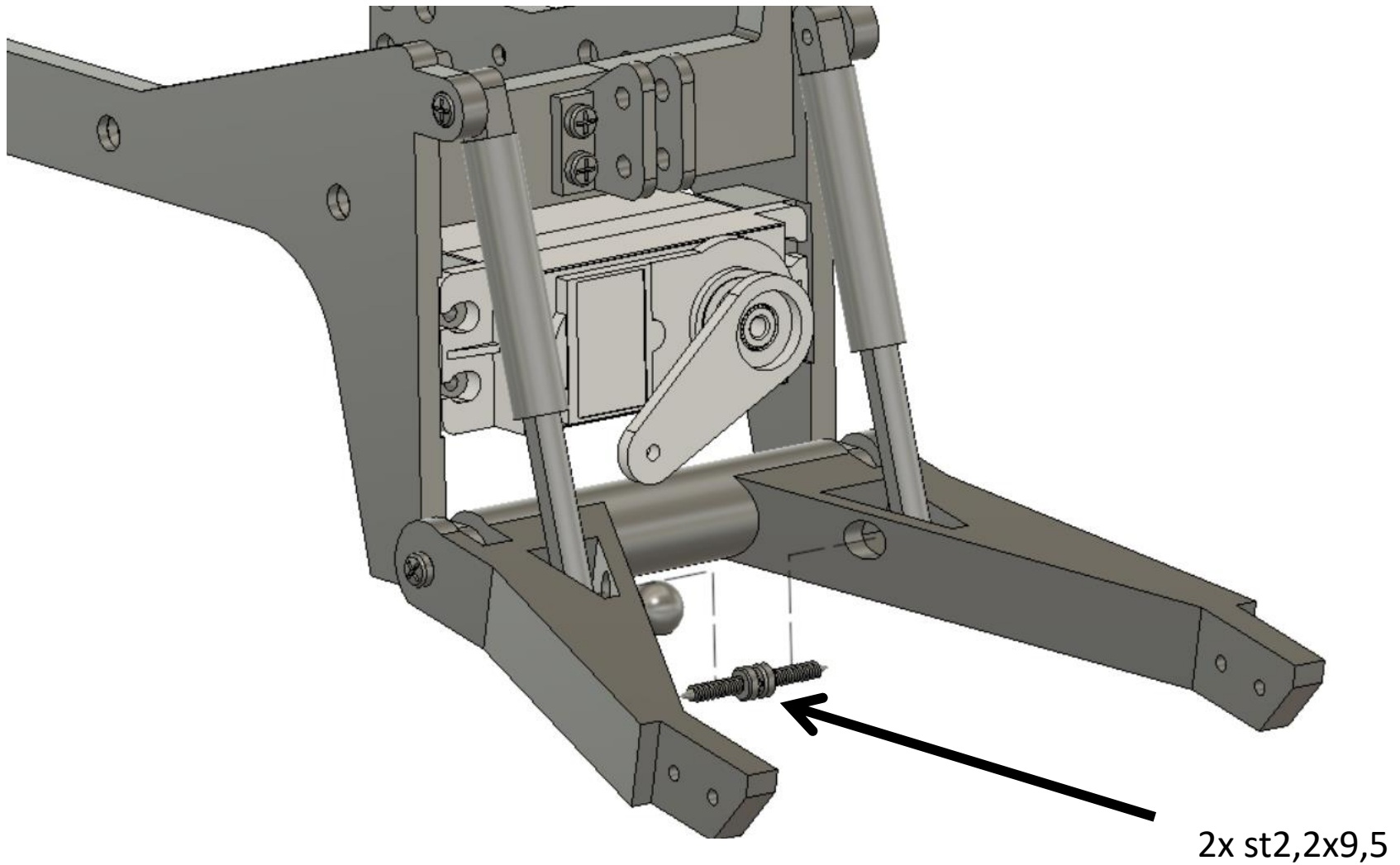

Krok/step 6

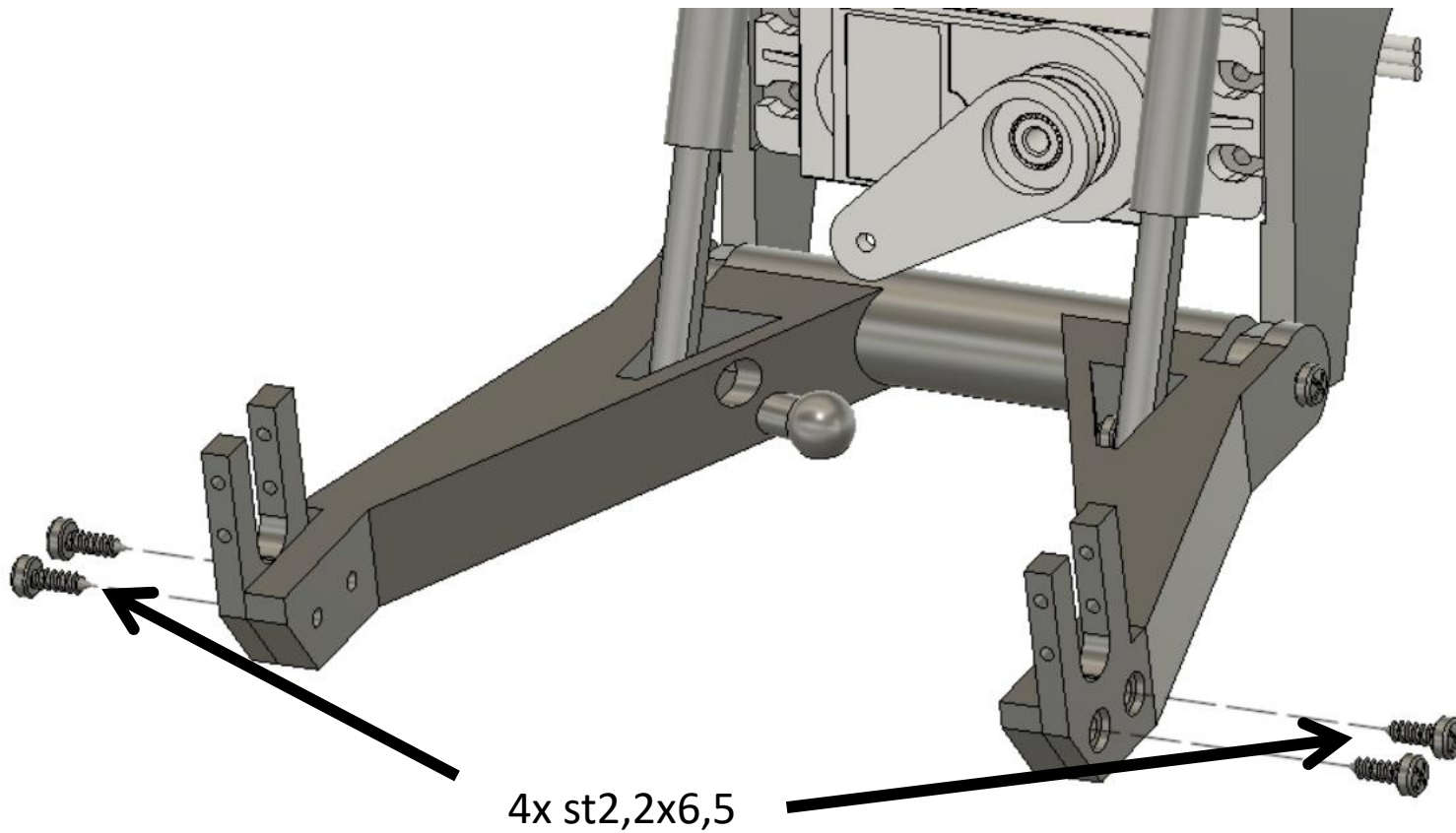

Krok/step 7

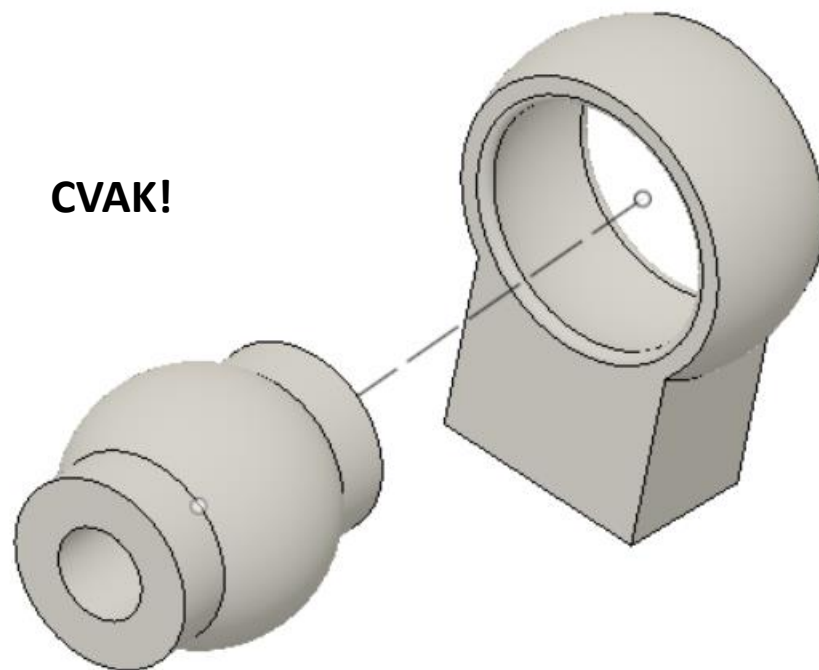

Krok/step 8

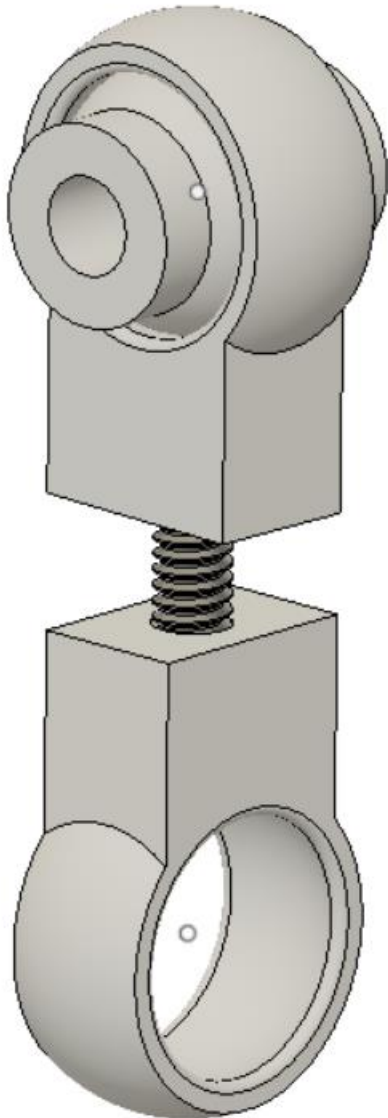

Pro spojení využijte šroub st2,2x13, která zašroubujete do spodní části a ucvaknete hlavičku. Poté zašroubujte horní část/ For the connection, use the st2.2x13 screw, which you screw into the lower part and cut the head. Then screw on the upper part

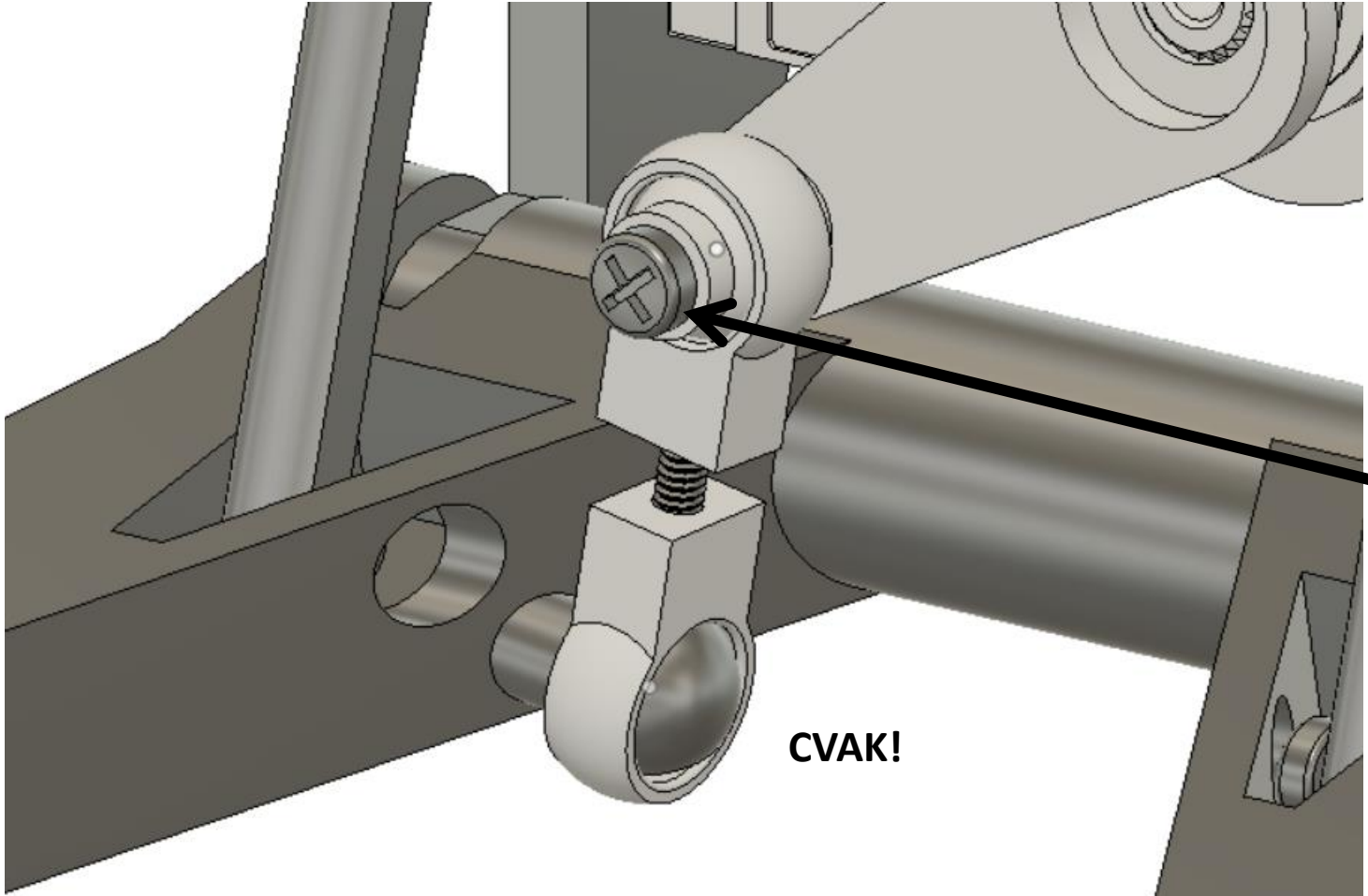

1x st2,2x13

CVAK!

Krok/step 9

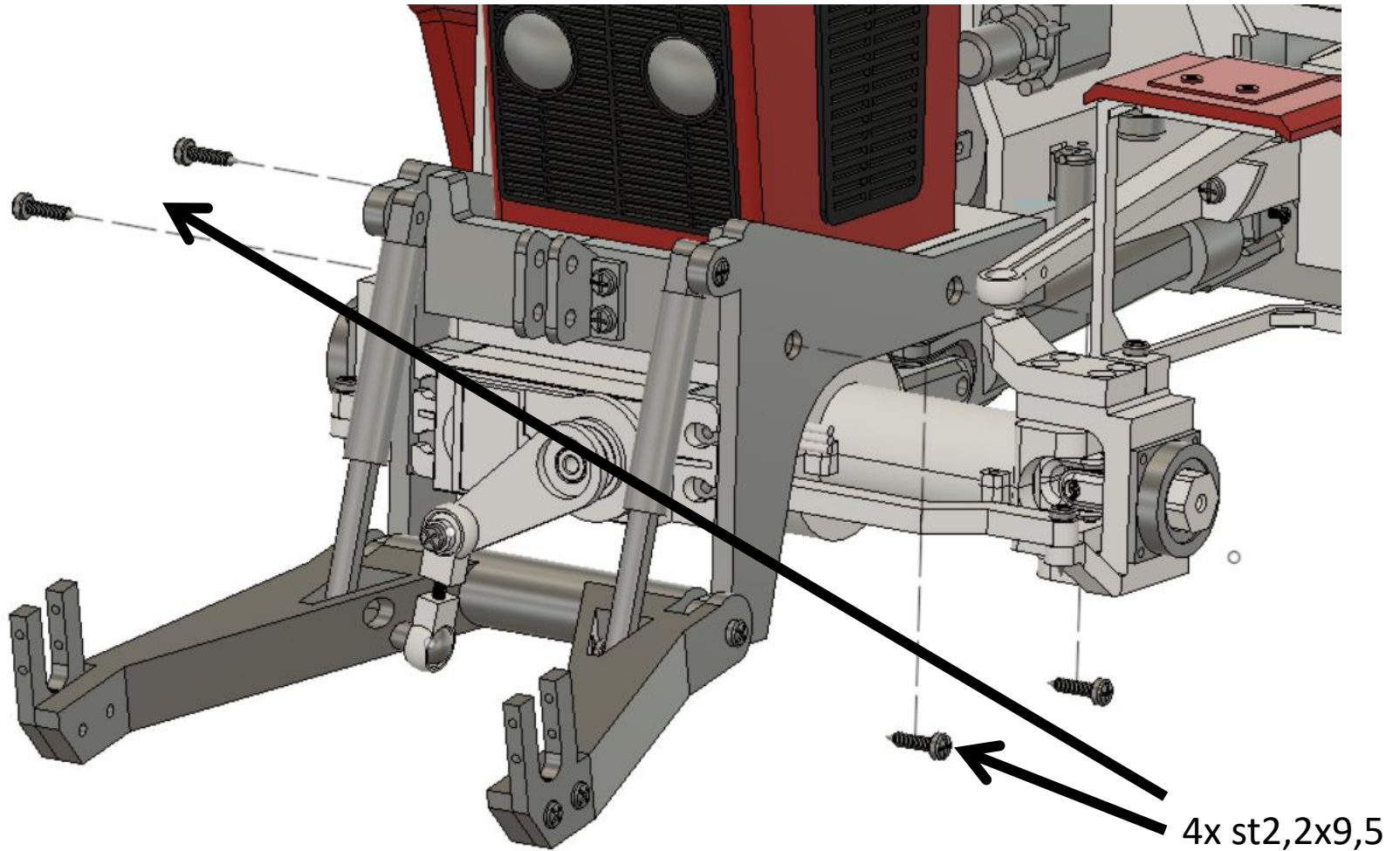

4x st2,2x9,5

Před sešroubováním k rámu přiložte a podle otvorů pro šrouby vyvrtejte díru o průměru 2mm do rámu traktoru/Before screwing on, attach to the frame and drill a 2 mm hole in the tractor frame according to the screw holes.

Krok/step 10

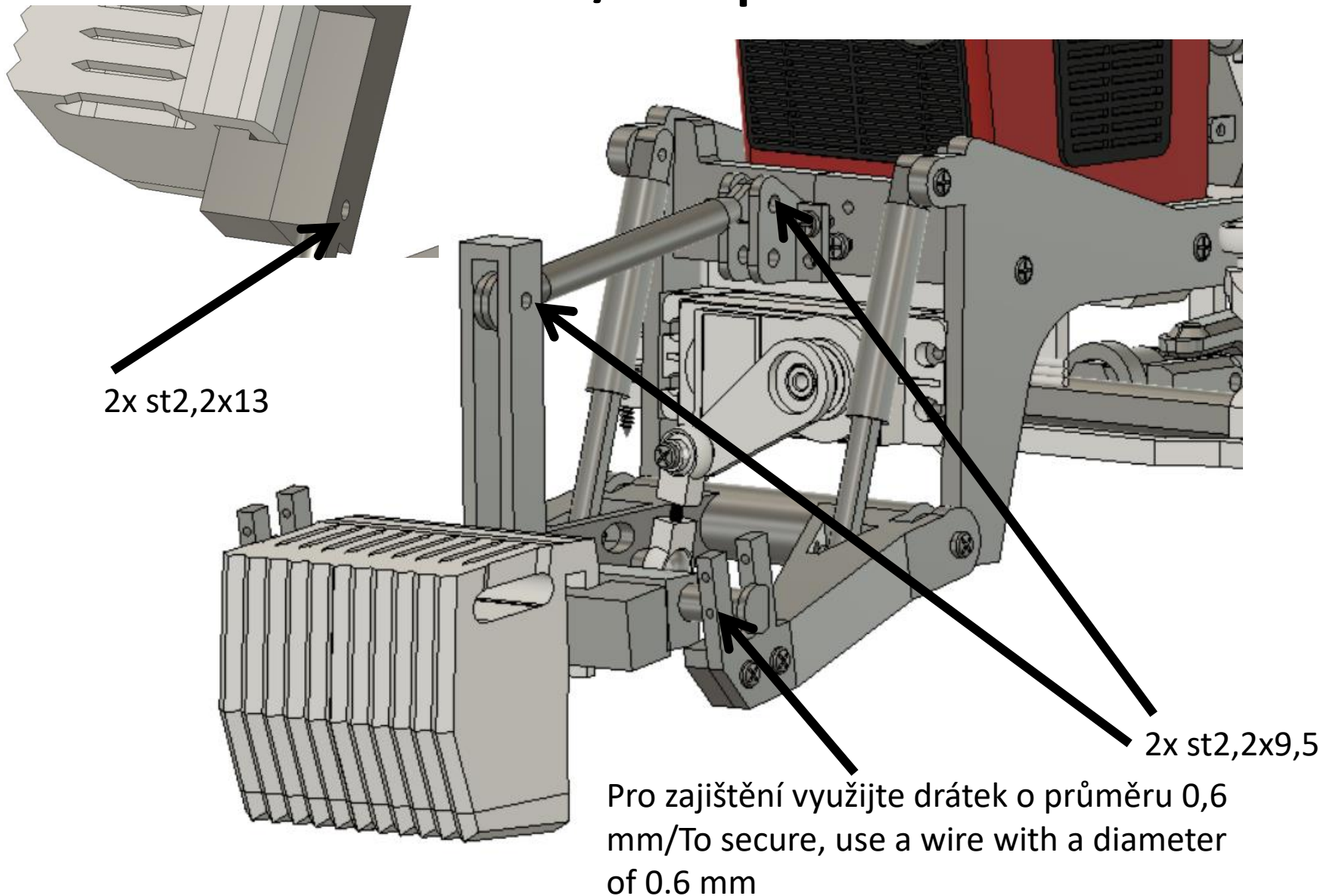

Krok/step 11

